

---

## Spherical Glass Target Microsatellite

V.D. Shargorodsky, V.P. Vasiliev, M.S. Belov, I.S. Gashkin, N.N. Parkhomenko

1. Institute for Precision Instrument Engineering, Moscow, Russia.

Contact: [www.niipp-moskva.ru](http://www.niipp-moskva.ru)

### Abstract

*A new SLR target microsatellite based on the optical Luneberg lens concept is now undergoing ground testing. It will be launched from the carrier spacecraft METEOR-M next year, and will be the first autonomous retroreflector satellite of this type, providing an extremely low target error.*

*Some parameters are presented of the microsatellite and its orbit, as well as far-field diffraction patterns measured on test bench.*

### Introduction

Most of the current SLR target satellites are spherical structures carrying a number of corner cube retroreflectors; with the rapid progress in SLR precision during the last decades, some disadvantages of such targets, being insignificant during the first years of SLR development, became increasingly more significant with the passing years.

The disadvantages are:

- It is difficult to obtain target errors less than 1 mm if return signals come from several cube corners having different positions relative to the CoM (Center of Mass) of the satellite.
- Even if the "one direction - one reflector" principle is used (e.g. in the WESTPAC or LARETS satellite design), the active retroreflector position varies relatively to the CoM, and the cube corner internal delay time also varies when the active retroreflector moves away from the line connecting the SLR system with the satellite CoM.
- The return signal strength varies significantly with the satellite rotation.
- The satellite shape is not an ideal sphere, especially for a design using the "one direction - one reflector" principle (WESTPAC, LARETS).
- Interaction with the Earth magnetic field (due to eddy currents induced in the massive metal body): slow-down of spinning, some disturbance of orbital motion.

There is a way to overcome the above difficulties. Instead of a multitude of corner cube prisms mounted on a spherical metal body, the target may be a single spherical retroreflector made of glass.

The initial idea was to use a device similar to the Luneberg lens proposed in 1944 and used in some radio-frequency systems (Figure 1). A planar electromagnetic wave coming from any direction is there focused on opposite surface of the spherical lens and if this surface is a reflective one, the device acts as a retroreflector.

Unfortunately, there are currently no suitable optical materials for correct implementation of such a device operating in the optical waveband.

A possible solution is using of a ball lens made of a glass with an index of refraction exactly equal to 2 (Figure 2). However, it requires a special extra-dense glass of a

high optical quality; this is currently a very hard task. Moreover, calculations show that only a small part of the ball aperture may be effectively used because of the spherical aberration.

The first practical solution was a two-layer glass ball, where the inner part is made of a flint glass having a relatively large index of refraction (1.75), while the outer layer is made of a crown glass with a low index of refraction (1.47). Such a device has been implemented and successfully tested showing acceptable retroreflector parameters [1] (Figure 3).

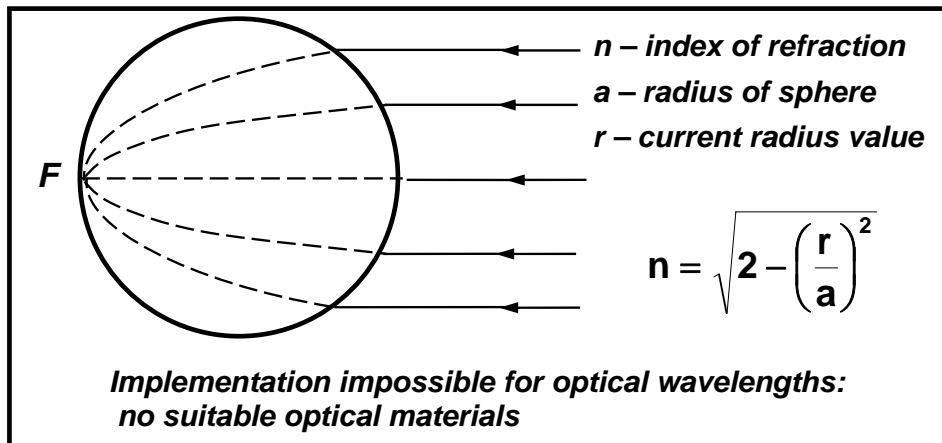


Figure 1. Luneberg lens principle

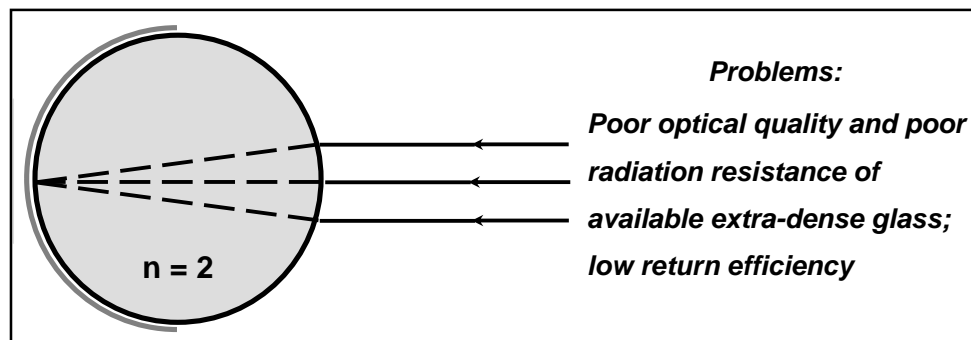


Figure 2. Ball lens made of glass with index of refraction  $n = 2$

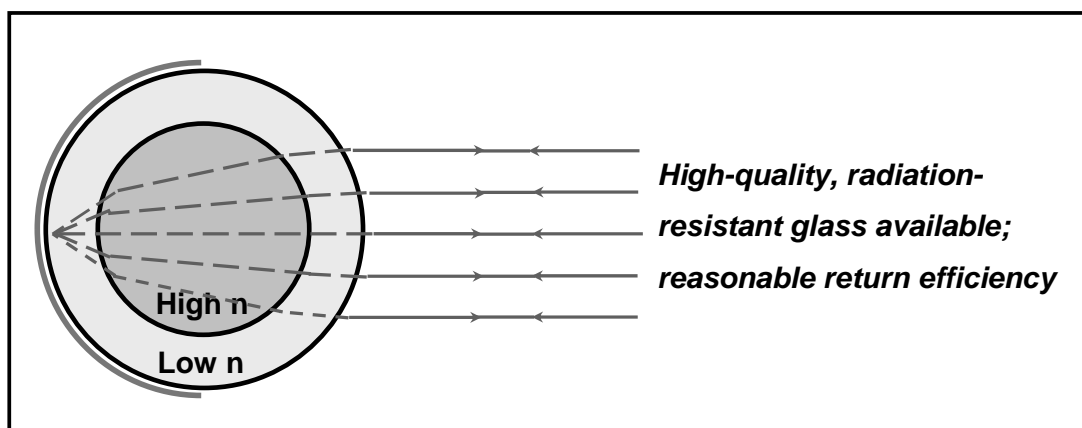
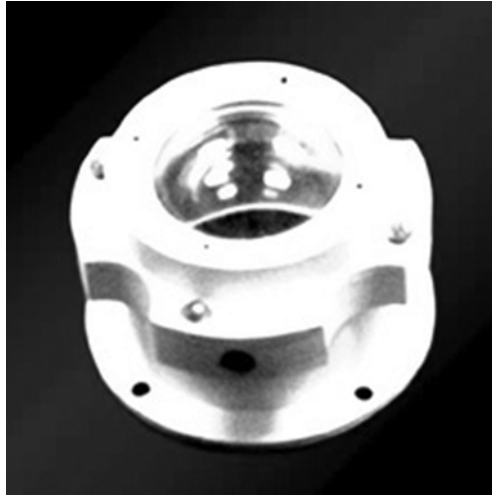


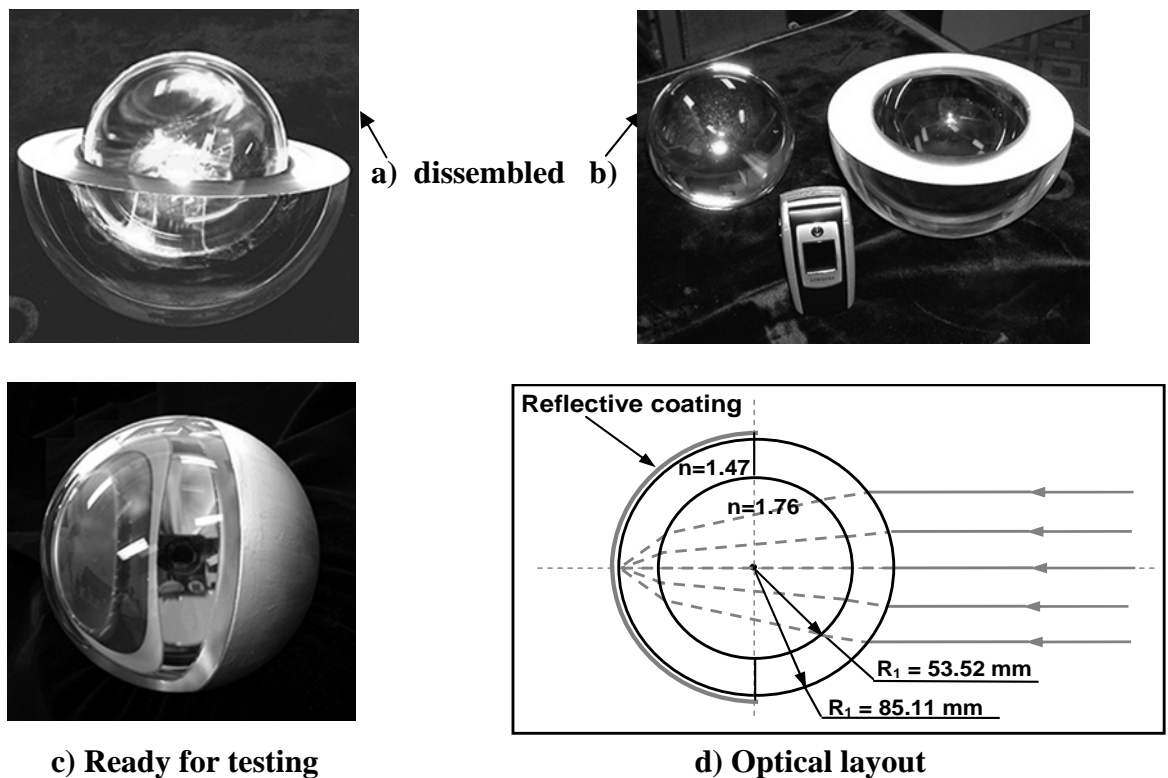
Figure 3. Spherical retroreflector: a two-layer ball lens

An experimental 60-mm-diameter spherical retroreflector of this type [2], after being tested in laboratory conditions, has been 10 December 2001 launched into space on board of the METEOR-3M(1) satellite having a 1018.5-km-high circular orbit (Figure 4). During four years of operation, the spherical retroreflector provided precision orbit determination for the SAGE-III experiment.

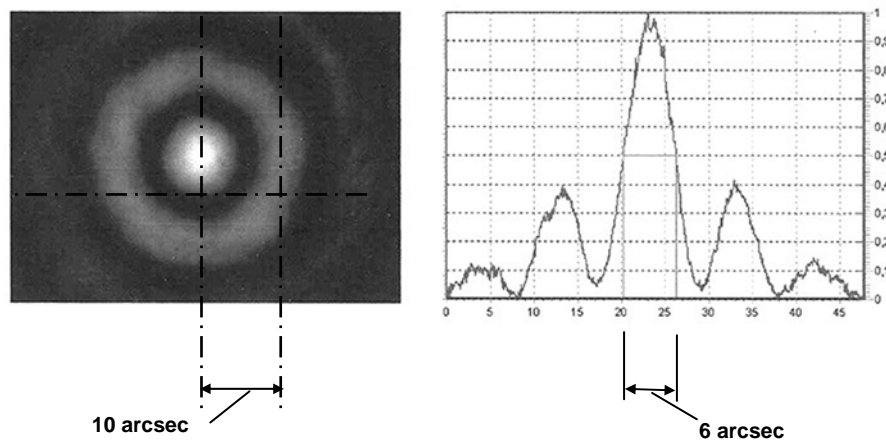


**Figure 4.** An experimental 60-mm-diameter spherical retroreflector, launched into space on board of the METEOR-3M(1) 10 December 2001

The lidar cross-section of this target was low (about  $10^4$  sq.m at the initial phase of flight), making SLR observations difficult and even impossible for a large part of the ILRS network stations.



**Figure 5.** 17-cm-diameter spherical retroreflector



**Figure 6.** Far-field diffraction pattern

We have therefore developed and fabricated a medium-size (17 cm in diameter) spherical retroreflector of this type, which can be used as an autonomous SLR target.

Figure 6 shows the far-field diffraction pattern of this device measured on a test bench. It can be seen from the picture, that most of the return signal energy is in the first-order side lobe (the product of its amplitude and solid angle is more than that of the center lobe).

It is intended to launch this device as an autonomous SLR target, as a piggyback load on the Meteor-M spacecraft. The basic parameters of this micro-satellite are shown in Table 1.

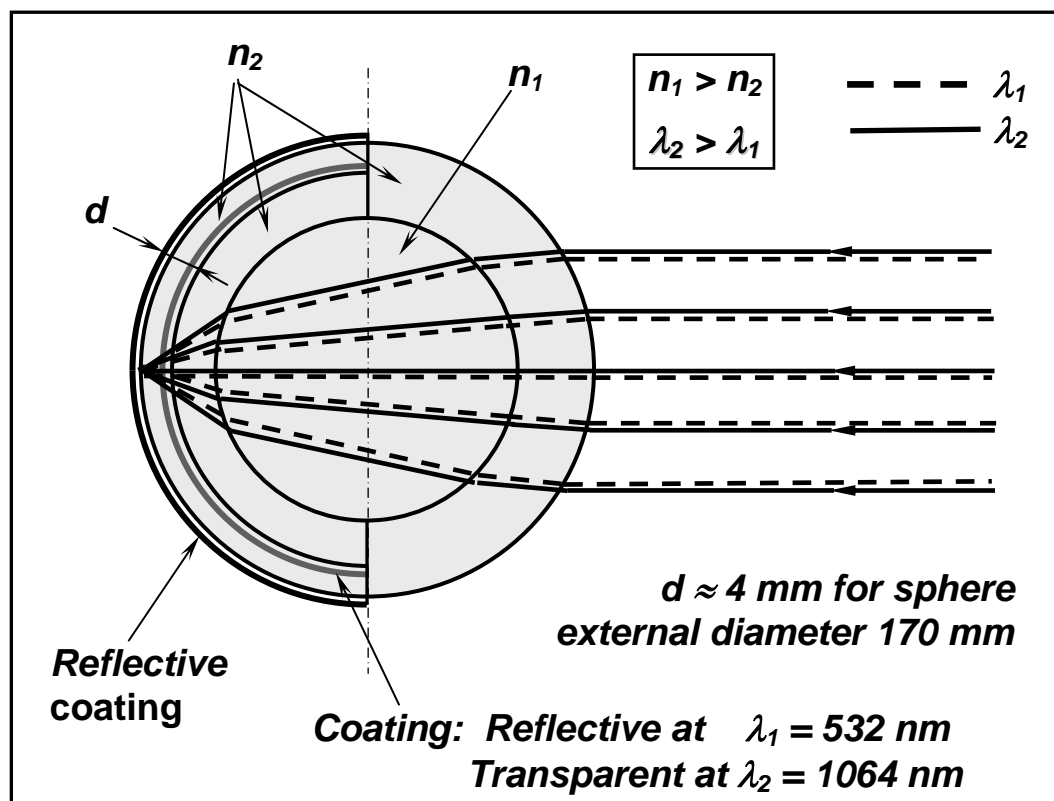
**Table 1.** Zero-signature spherical retroreflector micro-satellite

<i>Microsatellite parameters</i>	
Diameter	17 cm
Mass	7.45 kg
Cross-section	~100,000 sq.m at $\lambda=532$ nm
<i>Current status</i>	
Return pattern measurement under varying ambient conditions	
Separation system development	
<i>Mission</i>	
Carrier satellite	METEOR-M
Carrier satellite parameter	Height: 835 km (circular)
	Inclination: 99.7°
Planned launch date	Late 2007

The separation system (now under development) should provide a spin rate of at least 6 rpm, while the spin axis lies in the plane dividing the ball lens surface into the coated and uncoated parts.

SLR targets of this type may be improved in the following ways:

1. To increase the lidar cross-section, more than two layers of glass may be used. Calculations show that a three-layer ball lens may provide a significantly higher cross-section value than a two-layer one.
2. To provide operation on two widely separated wavelengths (e.g., 532 nm and 1064 nm), a design may be used shown in Figure 7. In the future, such an SLR-target may be attractive for minimization of the atmosphere refraction error using simultaneous two-wavelength ranging.
3. If (or rather when) super-dense optical glass with reflection index values  $\geq 2$  with good optical quality becomes available, it may be used for manufacturing of a ball-lens retroreflector microsatellite with a high mass to aperture cross-section ratio.



*Figure 7. Spherical retroreflector for operation at two widely separated wavelengths*

## References

- [1] Vasiliev V. P., Gashkin I. S., Belov M. S., Shargorodsky V. D., A New Approach to a Submillimeter SLR Target Design. Proceedings of 11<sup>th</sup> International Workshop on Laser Ranging, Deggendorf, Germany, Sep. 1998
- [2] Shargorodsky V. D., Vasiliev V. P., Soyuzova N. M., Burmistrov V.B., Gashkin I. S., Belov M. S., Khorosheva T. I., Nikolaev E. A. Experimental Spherical Retroreflector on Board of the Meteor-3M Satellite. Proceedings of 12<sup>th</sup> International Workshop on Laser Ranging, Matera, Italy, 2000